

THE EXPRESS BLOWER® TR-HD

With all the power of the full size TM-45HD or TM-70HD Express Blower® machines, this compact trailer version was designed for use in congested areas where you have access to continuous on-site loading. But don't let its original purpose limit you! Tow with a one-ton truck to any green roof, erosion control, or construction site for the blown-in installation of aggregates, soil blends, composts, mulches - go vertical more than 20 stories or distances up to 2,000 feet.

COMPACT. HEAVY DUTY. ROCK SOLID.



**Express
Blower®**

Web: www.expressblower.com

Toll Free: 800.285.7227

Direct: 541.434.7100

E-mail: info@expressblower.com

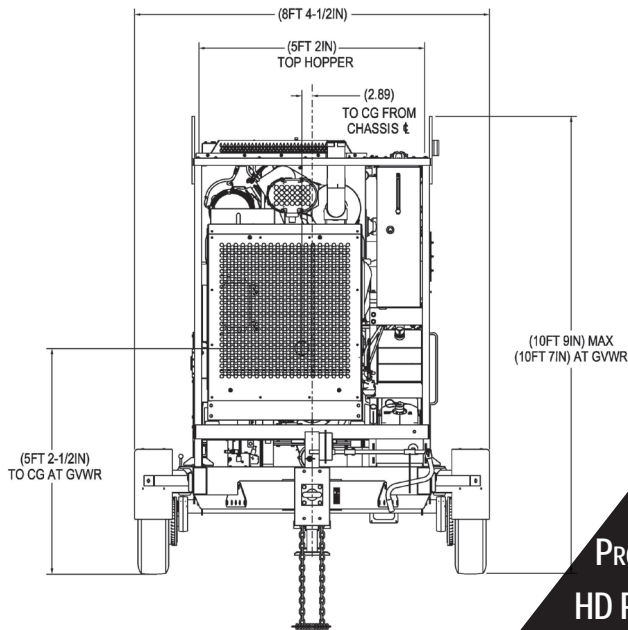
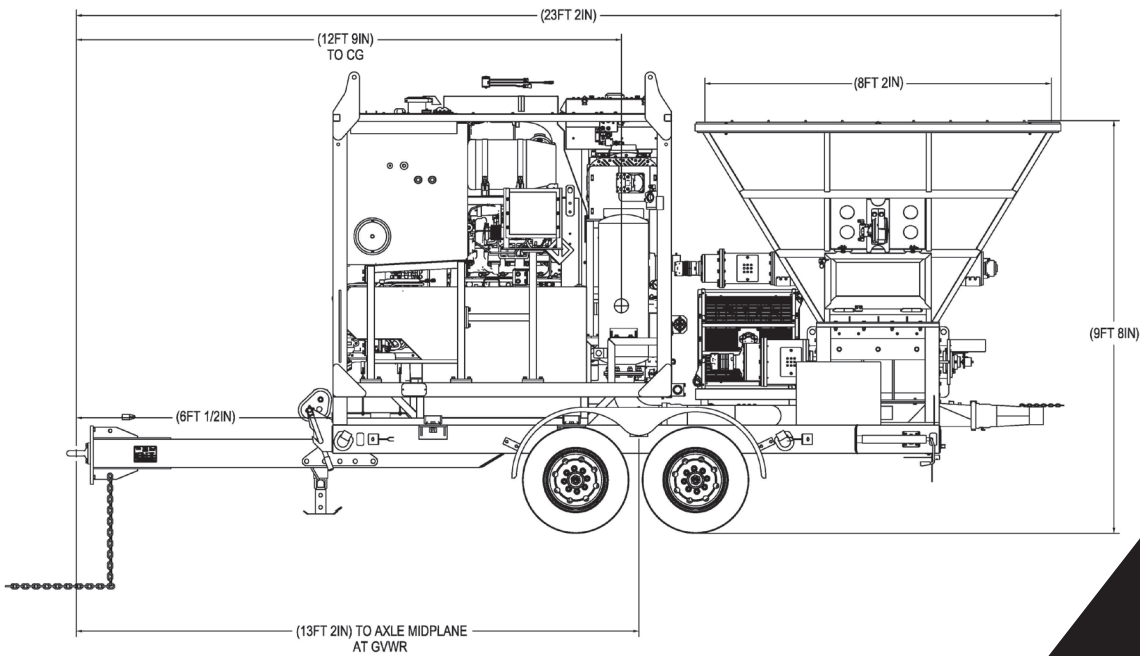

TR-HD SPECIFICATIONS

CONTROLS: EATON CONTROL SYSTEM

ENGINE: JD POWERTECH™ PSS 9.0L @ 350HP

BLOWER: 2400 CFM @ 20PSI

FUEL TANK CAPACITY: 80 GALLONS

HYDRAULIC TANK CAPACITY: 60 GALLONS

TOTAL WEIGHT: 18,920 POUNDS

HITCH: PINTLE HITCH WITH 7 PIN ELECTRIC HOOKUP

BRAKES: ELECTRIC BRAKES REQUIRE ELECTRIC BRAKE CONTROLLER

CAPABILITIES*

PRODUCT HAS BEEN BLOWN 2,000 FEET THRU EB BLOWER HOSE AND HARD PIPE

HD POWER WAS TESTED WITH FLEXIBLE HOSE AT 200 FEET:

3/4" ROUND ROCK: 48 TONS/HOUR

3/8" ROUND ROCK: 61 TONS/HOUR

3/4" CRUSHED ROCK: 35 TONS/HOUR

HD POWER WAS TESTED WITH HARD PIPE AT 200 FEET:

3/4" ROUND ROCK: 93 TONS/HOUR

3/8" ROUND ROCK: 125 TONS/HOUR

3/4" CRUSHED ROCK: 97 TONS/HOUR



Scan QR Code for Full Video



MATERIAL SIZE CAPABILITY: 1.5-INCH AGGREGATE

*CAPABILITIES MAY VARY DEPENDING ON MATERIALS, PROJECT PARAMETERS, AND OPERATOR EXPERIENCE.
 EXPRESS BLOWER AND THE EXPRESS BLOWER DESIGN LOGOS ARE TRADEMARKS OF EXPRESS BLOWER, INC.
 ©2023 EXPRESS BLOWER, INC. 06152023